

# Steel Chassis Cover (1451 Series)

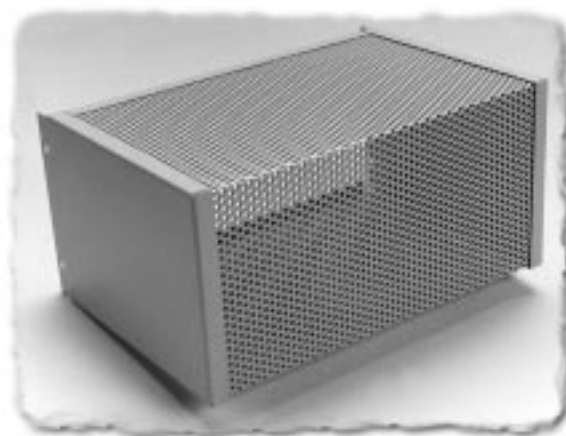
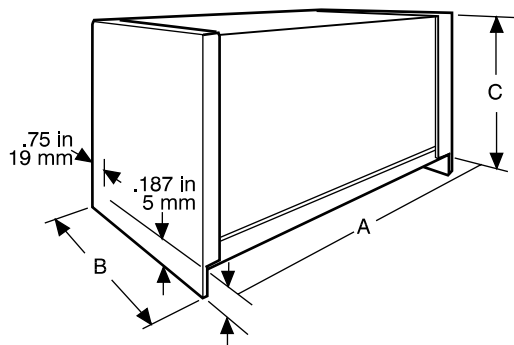

## KEY FEATURES

- For use with the 1441 and 1444 series chassis.
- 20 gauge steel ends welded to a perforated steel wrapper.
- ASA 61 grey baked enamel finish.
- 4 self-tapping screws included.
- Replacement screws **1421J6** (Pkg. of 6, 6-32 Philips head screws).

Part Number	Units	Dimensions			Use with Chassis
		A	B	C	
<b>1451-10</b>	inch	8	4	5.2	4 x 8
	mm	203	102	132	
<b>1451-14</b>	inch	9	5	5.2	5 x 9
	mm	228	127	132	
<b>1451-16</b>	inch	10	6	5.2	6 x 10
	mm	254	152	132	
<b>1451-22</b>	inch	12	8	5.2	8 x 12
	mm	305	203	132	
<b>1451-26</b>	inch	16	8	5.2	8 x 16
	mm	406	203	132	
<b>1451-30</b>	inch	17	10	5.2	10 x 17
	mm	432	254	132	

Metal



Hammond Manufacturing Co. Ltd.  
394 Edinburgh Rd. North  
Guelph, Ontario N1H 1E5 CANADA  
© Phone: 519-822-2960 Fax: 519-822-0715



Hammond Manufacturing Co. Inc.  
256 Sonwil Dr.  
Cheektowaga, NY 14225 USA  
Phone: 716-651-0086 Fax: 716-651-0726